

High frequency ignition unit ZT 930 24 VDC

For oil and gas dual burners of small to medium rating. With plug-in ignition and power supply cables, designed to fit beneath the burner safety control box.

INTRODUCTION

The ZT 930 24 VDC high frequency ignition transformer is suitable for use with oil, gas and dual fuel burners of small to medium rating. The power connector is compatible with the widely used 3-wire connector. A replacement with a plugable coil trafo is therefore possible without any problems.

CONSTRUCTIONAL FEATURES

A transistorised oscillator produces a high frequency voltage, which is then increased to 14 kV by a ferrite core transformer. The dimensions of the housing and fixing holes are such that it can be mounted underneath the burner control box wiring base. The power supply for the ZT 930 24 VDC is provided in the form of a 3 pin AMP type socket connection with a corresponding plug and cable supplied.

In order to meet all likely requirements, the ZT 930 24 VDC is available in 2 versions:

- ZT 930 24 VDC 4.0 mm pin to suit standard ignition cable connectors, e.g. for pre-assembled "Teflon" HT cables.
- ZT 930 24 VDC 1.0 mm pin to suit 7.0 mm silicon HT cable in conjunction with the Satronic clip.

INSTALLATION INSTRUCTIONS

The applicable regulations must be observed when mounting the device and carrying out the electrical connections. Particular attention must be given to method used to install the HT cables. Avoid unnecessary lengths, sharp bends over hard edges, extremely high temperatures etc., any of which could provoke ignition problems. For trouble-free operation, the correct spark gap at the ignition electrodes must be observed, supply voltage reductions and low ambient temperatures can cause problems if this is incorrect, see "Technical data" for recommended settings. The positioning of the HT ignition cables with regard to TV and radio interference is also extremely important. The cables should be kept short, run as close together as possible and should not cross or be in contact with any other power cables or fittings.

ATTENTION



Be careful to connect the power supply cables to the correct polarity!

24 VDC = brown
OV = blue



TECHNICAL DATA

Supply voltage	24 VDC (-25... +20%)
Connections:	3 plug type terminals
24V / 0V / PE	6.30 x 0.8 mm
High tension	ø 4 mm pin or ø 1 mm pin
Primary current	2.0 A
Rating	Intermittent, 25 % E.D. in 3 minutes
Ignition voltage	2 x 7 kV
Secondary current	17 mA rms
Secondary frequency	20 kHz
Spark gap	3 - 5 mm
Ignition cable	plug-in type
Insulation standard	IP 40
Permissible ambient temperature	-10° C... +60° C
Mounting attitude	any
Weight	180 g

ZT 930 24 VDC DIMENSIONS

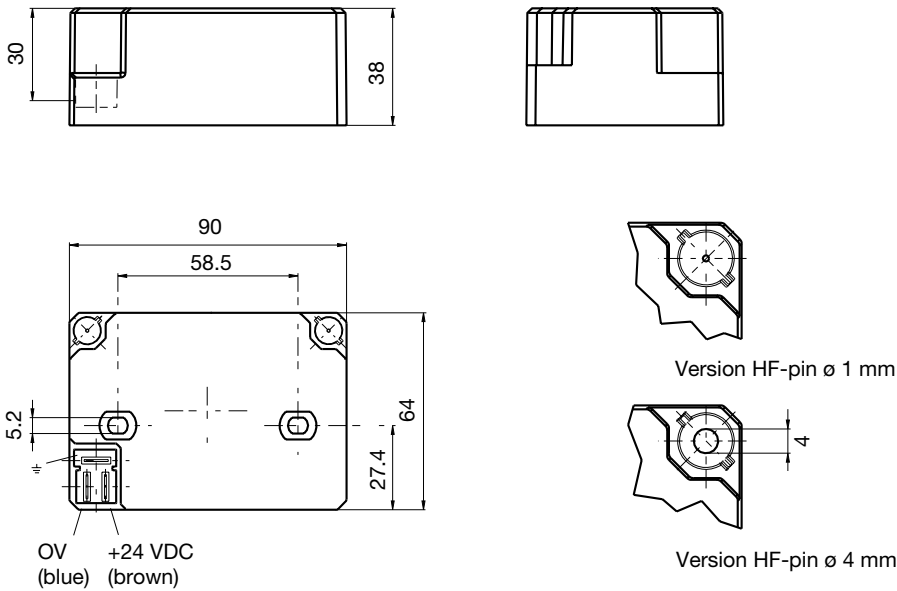

ZT 930 24 VDC SUPPLY CORD PLUG DIMENSIONS

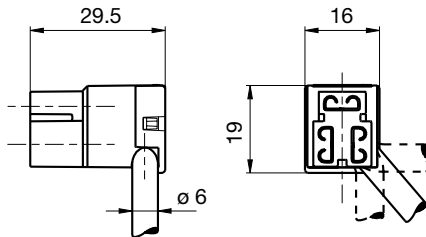

HIGH VOLTAGE CABLE CLIP DIMENSIONS

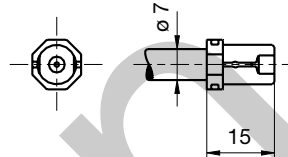

ORDERING INFORMATION

ITEM	DESIGNATION	ITEM NO.
Ignition Unit	ZT 930 24 VDC pin \varnothing 1 mm	13171
or	ZT 930 24 VDC pin \varnothing 4 mm	13174
Power supply cable	power cable ZT 930, 0.3 m	7283001
Ignition cable with clip, suitable for Item no. 13171	Silicon cable \varnothing 7 mm, 0.4 m	7274009
Clip separat to silicon cable	High Voltage Cable Clip	74993

The above ordering information refers to the standard version.
Special versions are also included in our product range.

Specifications subject to change without notice.

ZT 930 24 VDC